

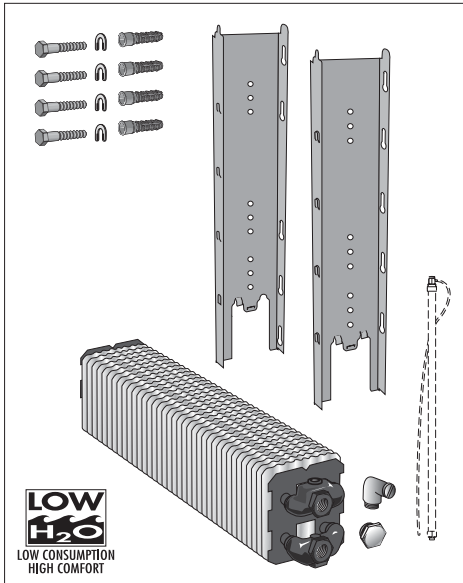

# WANDINBOUW ENCASTREMENT MURAL WANDEINBAU INSTALLATION INTO A WALL RECESS

*Energy*  
**SAVERS**  
**LOW-H<sub>2</sub>O**



**LOW H<sub>2</sub>O**  
LOW CONSUMPTION  
HIGH COMFORT

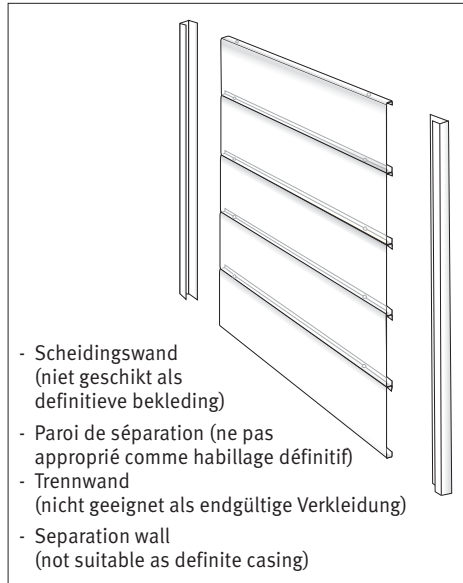

**OPTIE\_OPTION**

Verlengde ontluchter voor type 10, 15 en 20.  
Purgeur rallongé pour type 10, 15 et 20.  
Verlängerter Entlüfter für Typ 10, 15 und 20.  
Extended air vent for type 10, 15 and 20.

Hoogte bekleding Hauteur habillage Höhe Verkleidung Height casing	Code Art.-Nr.
20	5090.114078
30	5090.114178
40	5090.114278
50	5090.114378

## AFMETINGEN\_DIMENSIONS\_ABMESSUNGEN\_DIMENSIONS

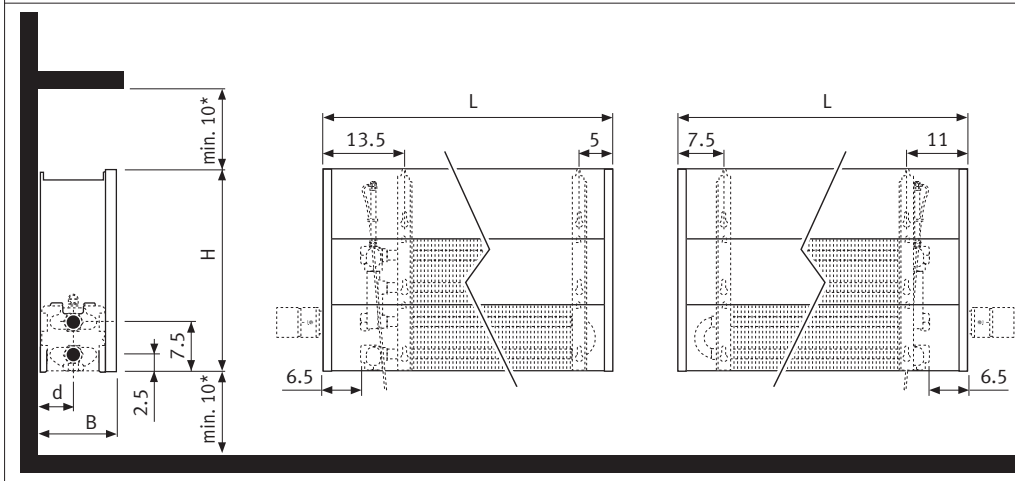

L	H
040	020
050	030
060	040
070	050
080	060
090	
100	
110	
120	
140	
160	
180	
200	
220	
240	
260	
280	
300	

DIMENSIONS in cm		
Type	B	d
10-11	11.8	5.3
15-16	16.8	7.8
20-21	21.8	10.3

\* Kleinere afstanden kunnen een daling van de afgifte tot gevolg hebben.  
\* Des dimensions inférieures peuvent diminuer l'émission de chaleur.  
\* Kleinere Abstände verändern die Wärmeleistung.  
\* Smaller dimensions decrease output.

## OPTIE\_OPTION VENTIELEN\_VANNES\_VENTILE\_VALVES

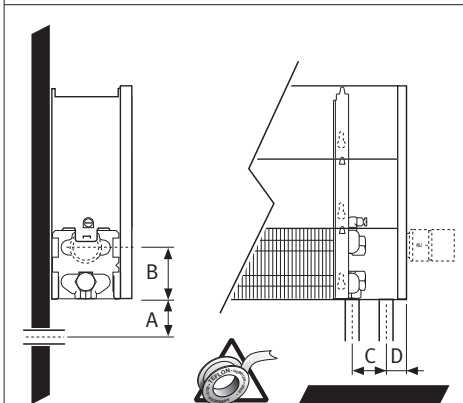

	A	B	C	D
EC 3/4"	3.5	--	5.0	3.0
M 24	4.5	--	3.8	1.5
G 1/2"	--	7.5	5.0	3.0

### Eurocone 3/4"

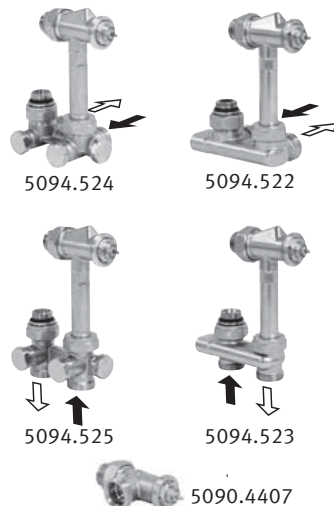

### M24



### G1/2"



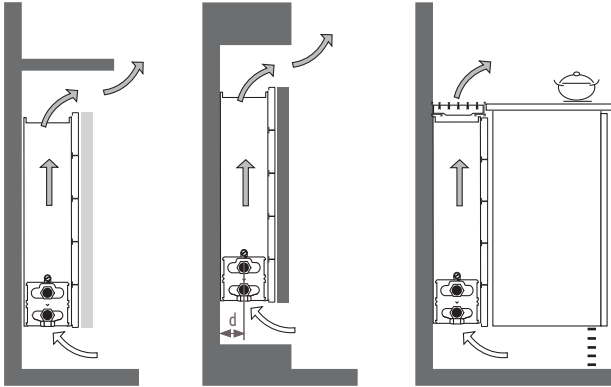

### Installatie

Construeer de kasten zodanig dat de warmtewisselaar bereikbaar blijft voor een jaarlijkse schoonmaakbeurt. Om te vermijden dat er vuil in de warmtewisselaar valt kan u best het rooster iets hoger plaatsen dan het werkblad.

### Placement

Construisez vos caches de manière à pouvoir dévisser la paroi arrière pour un nettoyage annuel. Posez la grille un rien plus haut que le plan de travail pour éviter les dépôts sur l'échangeur de chaleur.

### Montage

Konstruieren Sie die Verkleidungen so, daß Sie, wenn nötig, die Verkleidung für Wartung abschrauben können. Um bei Einbaueheizkörpern zu vermeiden, daß Schmutz in den Schacht fällt, den Rost etwas höher als die Ablagefläche vorsehen.

### Installation

Cupboards should be built in a way that enables acces to the heat exchanger for annual maintenance. In order to prevent dirt from falling into the heat exchanger, fit the grille a little higher than the cupboard edge.

